

TR 9650

Mobile bath Lift System



Knowing that each person is different - we design for maximum flexibility

The TR 9650 is a mobile bath lift system designed to easily convert into different configurations to accommodate a wide variety of needs for patients and residents in both the acute and long term care environments. Whether standing, seated or recumbent, the TR 9650 provides a dignified complete solution for residents needing aid getting in and out of bathtubs. Easy access and comfortable padded seating surfaces ensure a pleasant bathing experience.

Ergonomically designed hand grips and safety belts are incorporated into the TR 9650 to provide the security and assurance for both the attendant and the resident being bathed. By easily being convertible between a chair bath lift and a stretcher configuration, a greater resident or patient population can easily be addressed by the staff providing the bathing.

Converting between the chair configuration and the stretcher is a simple process that can be carried out by one individual and requires no tools. The wide and comfortably padded backrest and leg extension easily hinge onto the chair. Within minutes the TR 9650 can be changed to best accommodate the individual who is going to be bathed. The TR 9650 stretcher and chair have no dedicated head or foot so switching back and forth to accommodate individuals in different positions is a simple process.

TR designed into the TR 9650 caregiver-friendly foot controls so both hands are available to aid the bather while being lifted in and out of the bathtub. A smooth and quiet belt drive provides for safe and secure raising and lowering of the bather and large hospital grade castors make moving the lift effortless. All TR equipment incorporate stainless steel components to ensure a long functional and productive life.



Together with the TR bathtubs the Mobile bath lift system completes a system that offers a safe, labour efficient, person oriented bathing cycle with increased care quality.

TR EQUIPMENT

TR EQUIPMENT AB PO Box 116, S-573 22, TRANÅS, SWEDEN
TR GROUP INC. 2990 NORTH PERRYVILLE RD, SUITE 2300, ROCKFORD, IL 61107, USA
TR EQUIPMENT UK LTD. INNOVATION CENTRE, GALLOWS HILL, WARWICK CV34 6UW ENGLAND
TRANSPÖREHÄMAD GMBH GRÜNBAUMSTR. 89 42659 SOLINGEN. GERMANY

Phone: +46 140-38 50 60 Fax: +46 140-38 50 61
Phone: +1-800-752-6900 Fax: +1 815 633-0549
Phone: +44 844 335 8386 Fax: +44 844 335 8383
Phone: +49 (0) 212-645850-0 Fax: +49 (0)212-645850-50

Hygiene Equipment Designed for People

www.trequipment.com



TR 9650

Mobile bath Lift System

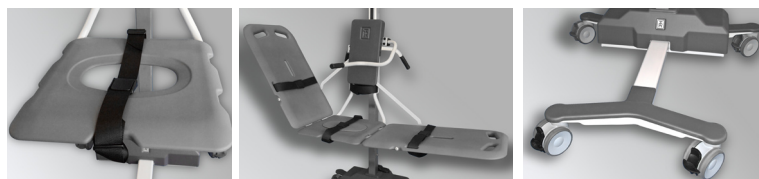

Commode seat on chair which can be covered by included lid.

Comfortable and easy to clean laying and seating surfaces.

Narrow chassis design for easy and safe transfers.



Comfortable back rest that can easily be moved to either arms for back support.

Attachable stretcher side parts for easy conversion from stretcher to chair. No tools required

Emergency stop button and magnetic battery charger connection for safety and ease of use.

Specifications

Operating height range	200 - 965 mm (8 - 38")
Working Load Limit	150 kg (330 lbs)
Structure	Powder coated, zinc plated steel and stainless steel
Castors	Twin Ø100 mm (4") castors, two with brakes and two with straight steering
Control	Foot control for height adjustment
Stretcher, pillow	Flame retardant material
Battery	Rechargeable, 24 V

CE Registered at Medical Products Agency, Sweden, as a MD Class 1, MDD 93/42EEC.

Features

- Seating and stretcher surfaces made of a soft, durable material that is non water absorbent which makes it easy to clean, maintain and are very comfortable to sit and lay on
- Removable side parts provide a simple configuration from chair to stretcher
- The safety arm support in both the chair and stretcher configurations can be folded away for easy access and moved back once the bather is in position
- The leg configuration is designed for easy individual approach onto the chair and stretcher
- A low chassis is designed for easy access under beds and baths
- A safety stop engages automatically if the chair or stretcher is lowered onto any surfaces or obstacles
- An integral Autostop ensures that the seat and stretcher can not drop, should the belt fail
- Magnetic battery charger connection designed to prevent damage should the connection accidentally not be unplugged as well as making charging a simpler task
- Audible low battery tone
- Ready for use after unpacking and comes complete with battery charger and safety belts
- TR 9650 can be used together with almost all supine bath tubs and therapy. An optional spacer can be optioned for changing or improving the location of the bath lift into the tub
- Additional features: Foot activated emergency stop. High capacity rechargeable batteries. Large castors with locking and straight steering

Models

Bath chair lift. Art.no. 0542000 incl. battery charger
 Bath stretcher lift. Art.no. 0542010 incl. battery charger
 Bath combi lift with chair. Art.no. 0542020 incl. battery charger
 Two Stretcher side parts for combi lift with chair incl. pillow. Art.no. 0542030

Option

TR Scale 1650

Accessories

Extension adapter to increase distance from lift column to chair / stretcher (60 mm)

Chairlift:

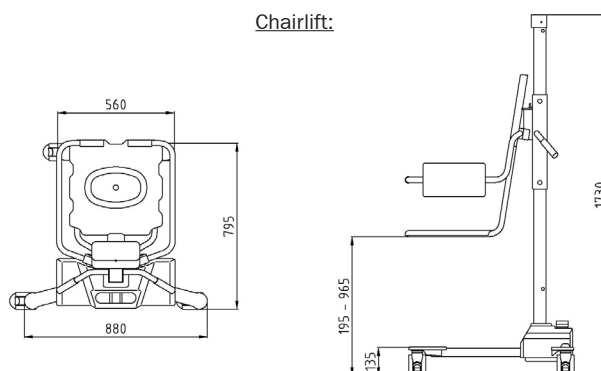

Stretcher/Combilift::

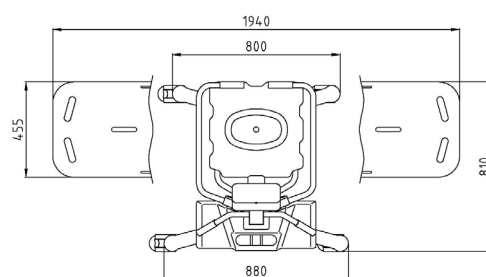

TR reserves the right to make design changes and/or improvements without notice

Distributor:

Manufacturer: TR Equipment AB

TR EQUIPMENT

TR EQUIPMENT AB

PO Box 116, S-573 22, TRANÅS, SWEDEN

Phone: +46 140-38 50 60

Fax: +46 140-38 50 61

TR GROUP INC.

2990 NORTH PERRYVILLE RD, SUITE 2300, ROCKFORD, IL 61107, USA

Phone: +1-800-752-6900

Fax: +1 815 633-0549

TR EQUIPMENT UK LTD.

INNOVATION CENTRE, GALLOWS HILL, WARWICK CV34 6UW ENGLAND

Phone: +44 844 335 8386

Fax: +44 844 335 8383

TRANSPÖREHAMED GMBH

GRÜNBAUMSTR. 89 42659 SOLINGEN. GERMANY

Phone: +49 (0) 212-645850-0

Fax: +49 (0)212-645850-50

www.trequipment.com



Hygiene Equipment Designed for People